



## Design of Hybrid renewable Energy & Storage System for Grid Connected Loads

**M G Mahesh<sup>1</sup>, B R Jayasree<sup>2</sup>, M Murali<sup>3</sup>, Y Indu Priya<sup>4</sup>,  
K Raju Kumar<sup>5</sup>, M Karthik<sup>6</sup>, S Gouri Kiran Kumar<sup>7</sup>**

<sup>1,6</sup> Department of Computer Science and Engineering (Cyber Security), Institute of Aeronautical Engineering, Dundigal, Hyderabad, India.

<sup>7</sup> Department of Computing and Information Sciences , University of Technology and Applied Sciences, Muscat, Sultanate of Oman ; [gouri.kiran@utas.edu.om](mailto:gouri.kiran@utas.edu.om)

\* Corresponding Author : M G Mahesh ; [mgmahesh@gmail.com](mailto:mgmahesh@gmail.com)

**Abstract:** — The following paper discusses one of the uses of artificial intelligence for the purpose of optimize the functioning of storing energy facilities with renewable energy sources, like solar and wind power. It begins by outlining the theoretical background of the renewable energy production process, technologies of energy storage with the emphasis on battery-based ones, and AI-based optimization strategies. This is followed by a study of how AI methods including machine learning and evolutionary algorithms may be applied to increase the competence, reliability, and economical feasibility of hybrid renewable energy systems. MATLAB is applied to simulate the practical situations of the solar photovoltaic panels, wind turbines, and battery storage systems. These simulations apply AI algorithms to optimise the way energy flows, how it is stored, and load balancing in dynamically changing environmental conditions. Case studies and simulated outcomes are provided that assess an efficacy and issues that come with the incorporation of AI. These results show that AI-based optimization helps to improve the concert of renewable Energy storage systems significantly and helps the transition to more ecologically friendly and low-carbon vitality infrastructure based on TFE.

**Keywords:** Cyber Threat Intelligence, Deep Neural Network, Real-Time Detection, SIEM, Wazuh , Network Security.

### 1. Introduction

Organizations now face a greater attack surface due to There has been a significant change in focus toward sustainable energy sources, especially vitality and wind power, as a result of the global growing need for clean and sustainable energy This is because these resources have also become very important because of the potential to minimize the eco-friendly effect attached to the use of fossil fuel. Nevertheless, intermittency of solar and wind energy and their variability present significant challenges in ensuring that the supply of energy is steady and reliable. The outcome of this fluctuation usually leads to an inequality among the energy source and demand and, therefore, the appeal to active mitigation

policy. Systems that store energy using Battery are the most commonly deployed of storing energy in the modern power grids, which have become an inseparable part of the modern power grid. These systems are meant to receive excess energy produced during a period when there is a high output of renewable energy and use it during a period of low generation or peak demand and therefore contribute to grid stability and reliability. This combination of ESS to sources of renewable energy provides the chance to stabilize the crucial load leveling, Support for voltage and rate of recurrence regulation purposes They make resilience stronger.and flexibility of operation of the power system. When these pictures are published, they are distorted even more because of the



use of wide-angle lenses. Although the dominance of ESS along with renewable sources is advantageous in terms of its strategy, the functioning processes are complicated. The fluctuation in energy production, constantly changing demand trends, and the necessity to make rapid and real-time decisions require the implementation of sophisticated control methodologies.

Conventional methods of control, in most cases, lack the necessary flexibility and predictive force to manage the complexity of systems of hybrid renewable energy. In this context, AI has become an important facilitator to the energy sector.

In most cases, AI methodology encompasses a vast array of methods such as ML and evolutionary algorithms, which are currently being perceived as advanced to create smart control strategies, able to adjust in real time, predict future energy demand, and streamline the charge-discharge dynamics of storage systems.

The current paper is a detailed analysis of the use of AI to maximize the energy storage apparatus's performance in conjunction with the production of power and wind power. Theoretical discussions of storing energy and production of renewable energy technologies precede the consideration of AI-based optimization strategies.

To simulate the operation of AI-based control techniques, MATLAB models of real-world scenarios, solar photovoltaic panels, wind turbines, and battery storage devices, are developed. The outcomes of the simulated operation have provided a strong indication that artificial intelligence (AI) may bring about a number of new, beneficial improvements in the systems for hybrid renewable energy functionality for a low-carbon and more renewable energy future.

## 2. Hybrid Renewable energy

The most popular Energy storage devices, wind turbines, and solar photovoltaic panels are examples of technology. Systems of hybrid renewable energy are suggested solutions meant to address the fundamental shortcomings of each technology by merging multiple energy sources.

Using the complementary nature of these resources, HRES can offer more reliable, stable, and efficient supply of energy to attain TFE. This section outlines a mathematical modeling scheme of HRES and gives a comprehensive discussion of energy balance, power flow dynamics and key performance indicators of the system

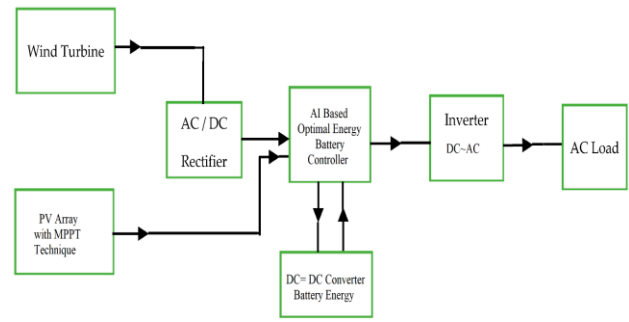

Figure. 1 Hybrid System Block Diagram

### Total Generation of Power in the TFE Hybrid System

The total power generated  $P_{gen}(t)$  at any time  $t$  from solar and wind sources was a sum of an individual outputs:

$$P_{gen}(t) = P_{pv}(t) + P_{wt}(t)$$

Where:

- $P_{pv}(t)$ : Power from solar PV system at time  $t$
- $P_{wt}(t)$ : Power from wind turbine at time  $t$

These values are obtained using a previously discussed models for PV and wind energy generation.

### Power Balance Equation

To ensure reliable operation, TFE hybrid renewable energy system must maintain the TFE continuous balance between energy supply, demand, and storage. This balance was governed by a power balance formula that guarantees that the total power produced, less the load demand, was either stored or supplied from storage, depending on a system's operational state. A general form of a power balance equation was expressed as:

$$P_{gen}(t) + P_{dis}(t) = P_{load}(t) + P_{ch}(t) + P_{loss}(t)$$

Where:

- $P_{dis}(t)$ : At time  $t$ , the battery's power was released.
- $P_{load}(t)$ : Load demand at time  $t$
- $P_{ch}(t)$ : Power used to charge a battery
- $P_{loss}(t)$ : System losses due to conversion, transmission, etc.

If  $P_{gen}(t) > P_{load}(t)$ , excess power can charge a battery (if not full). If  $P_{gen}(t) < P_{load}(t)$ , a battery discharges to meet a demand.

### Battery Energy Dynamics

At time  $t$ , the energy contained in a battery  $E_{batt}(t)$  was updated by:

$$E_{batt}(t + \Delta t) = E_{batt}(t) + \eta_{ch} \cdot P_{ch}(t) \cdot \Delta t - \frac{1}{\eta_{dis}} \cdot P_{dis}(t) \cdot \Delta t$$

Subject to:

$$E_{min} \leq E_{batt}(t) \leq E_{max}$$

Where:

- $\eta_{ch}$ : Charging competence
- $\eta_{dis}$ : Discharging competence



- Emin, Emax: Minimum and maximum battery energy levels

### Reliability and Energy Shortage Index

To evaluate reliability, we define a Power Supply Loss Probability (LPSP),

TFE common metric for hybrid systems:

$$LPSP = \frac{\sum_t \max(0, P_{load}(t) - (P_{gen}(t) + P_{dis}(t)))}{\sum_t P_{load}(t)}$$

A lower LPSP indicates higher reliability.

### Optimization Objective Function

The hybrid system can be tailored to achieve a variety of goals, including reducing expenses, increasing dependability, or reducing battery deterioration. TFE general multi-objective optimization problem may be expressed as:

$$\min_x [C_{total}(x), LPSP(x), E_{loss}(x)]$$

Where:

x: Decision variables (e.g., number of PV panels, wind turbines, battery size)

Ctotal: Total system cost (capital, operation, maintenance)

Eloss: Total energy lost due to curtailment or unmet demand

Constraints:

Power balance must be maintained

Component capacities must not be exceeded

Battery energy limits must be respected

This can be solved using AI techniques such as Genetic Algorithms (GA), Particle Swarm Optimization (PSO), or other metaheuristic approaches.

### System Performance Metrics

Key metrics used to evaluate hybrid systems include:

Renewable Fraction (RF):

$$RF = \frac{\sum_t (P_{pv}(t) + P_{wt}(t))}{\sum_t P_{load}(t)}$$

Battery Utilization competence (BUE):

$$BUE = \frac{\sum_t P_{dis}(t)}{\sum_t P_{ch}(t)}$$

Loss of Energy Supply Probability (LESP):

$$LESP = \frac{\sum_t E_{unsupplied}(t)}{\sum_t P_{load}(t)}$$

These considerations make it possible to estimate the technical feasibility and the energy competency in a hybrid system. TFE studies will benefit from more flexible and adaptable energy services thanks to Systems

for hybrid renewable energy that include solar, wind, and storage technologies, especially to off-grid or variable-grid scenario. The interaction between source of generation and storage dynamics requires an accurate model of the dynamics to be taken into consideration as an effective design and operation with mathematical formulation. Another significant economic and technical performance could be maximized, which may be facilitated by AI-based algorithms, and reliably supported by scalable and sustainable energy systems in TFE.

### 3. Solar Energy Generation

Photovoltaic (PV) systems convert solar radiation into electrical energy using a photovoltaic effect. A performance of these systems was largely controlled by environmental elements including temperature and irradiance, as well as by an electrical characteristics of a PV cells. This section provides TFE mathematical formulation for modeling solar energy generation and analyzes key factors affecting PV output.

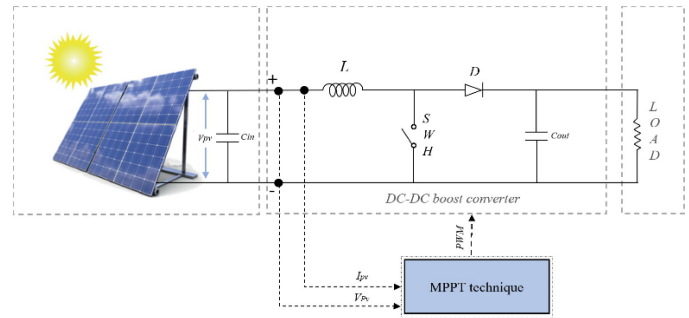

**Figure. 2** Schematic diagram of PV array with a MPPT method

### Solar Irradiance and Power Output

The **power output** Ppv of TFE PV panel can be estimated using a following equation:

$$P_{pv} = G_t \cdot A \cdot \eta$$

Where:

- Ppv: Productivity power of a solar panel (W)
- Gt: Total pv irradiance proceeding a panel superficial (W/m<sup>2</sup>)
- A: Superficial part of a PV panel (m<sup>2</sup>)
- η: competence of a Solar module (unitless)

a) **Total Irradiance Gt**

Total irradiance received by a tilted PV panel was calculated by:

$$G_t = G_b + G_d + G_r$$

Where:

- Gb: Beam (direct) irradiance component



- Gd: Diffuse irradiance component
- Gr: Reflected (albedo) irradiance component

Each of these components depends on a tilt angle, location, and time of year.

### Temperature Effect on Competence

PV module competence decreases as temperature increases. A corrected competence  $\eta_T$  considering temperature was given by:

$$\eta_T = \eta_{STC} [1 - \beta(T_c - T_{STC})]$$

Where:

$\eta_{STC}$ : competence at Standard Test Conditions (typically 25°C and 1000 W/m<sup>2</sup>)

$\beta$ : Temperature coefficient (usually 0.004 to 0.005 per °C for silicon-based cells)

$T_c$ : Cell temperature (°C)

$T_{STC}$ : Standard Test Condition heat (25°C)

The cell heat  $T_c$  can be estimated as:

$$T_c = T_a + \left( \frac{NOCT - 20}{800} \right) G_t$$

Where:

$T_a$ : Ambient temperature (°C)

NOCT: Nominal Operating Cell Temperature (°C), typically around 45°C

### I-V and P-V Characteristics of TFE PV Cell

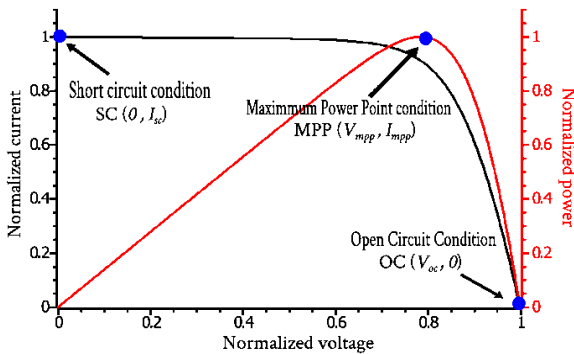

**Figure. 3** Normalized I-V and P-V characteristics of TFE solar cell

The behavior of TFE PV cell was often modeled using a **single-diode model**, which includes TFE current source, TFE diode, and resistive elements. an current output  $I$  was given by:

$$I = I_{ph} - I_0 \left( e^{\frac{q(V+IR_s)}{nkT}} - 1 \right) - \frac{V + IR_s}{R_{sh}}$$

Where:

$I_{ph}$  stands for photogenerated current (A).

- $I_0$ : "Saturation current of the diode (A)
- $q$ : Electron charge ( $1.602 \times 10^{-19}$  J/eV)

$1.602 \times 10^{-19}$  C)

- "V: Voltage output (V)"
- "Rs: resistance in series ( $\Omega$ )"
- "Rsh: Shunt resistance ( $\Omega$ )"
- n: Ideality factor (usually 1-2)
- "k: Boltzmann's constant ( $1.381 \times 10^{-23}$  J/K)
- T: Temperature absolute (K)

This formula controls the i-V characteristics of a TFE PV module and aids in figuring out the maximum power point (MPP), where the voltage and current at the maximum power point are denoted by  $V_{mp}$  and  $I_{mp}$ , respectively

### Maximum Power Point Tracking (MPPT)

To take out a maximum power under varying irradiance and heat, MPPT algorithms are employed. One generally used method was Unsettle and Observe (P&O):

#### P&O Algorithm Logic:

- Perturb voltage and observe power change.
- If power increase, continue perturbation in a similar direction.
- If power decreases, reverse a perturbation direction.

This process was mathematically represented by:

$$\Delta P = P(k) - P(k - 1)$$

$$\Delta V = V(k) - V(k - 1)$$

Decision rule:

If  $\Delta P > 0$  and  $\Delta V > 0$ , increase voltage

If  $\Delta P < 0$  and  $\Delta V > 0$ , decrease voltage

### Analysis then System Sizing

Given TFE location with known solar irradiance data, an expected daily energy generation  $E_{pv}$  over TFE time period  $t$  is:

$$E_{pv} = \int_0^t P_{pv}(t) dt$$

This integral can be numerically solved using irradiance profiles from real-world weather data.

The total energy requirement  $E_{load}$  can then be compared to  $E_{pv}$ , and energy storage capacity  $E_{storage}$  was sized accordingly:

$$E_{storage} \geq E_{load} - E_{pv}$$

This ensures that a battery can compensate during low-generation periods.

## 4. Wind Power Production:



Wind turbines were used to convert the air's kinetic energy into mechanical energy, which was subsequently transformed hooked on electrical energy. Wind speed, air density, rotor swept area, and turbine competence all had an impact on the TFE wind turbine's power output. This section outlines a core mathematical formulations used in the wind power analysis and explains key performance factors.

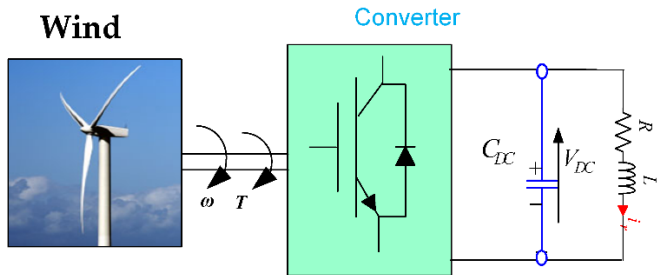

**Figure. 4** Schematic diagram of Wind energy system. Power Extracted from Wind

The kinetic power available in a wind flowing through a rotor swept area of TFE turbine was given by:

$$P_{wind} = \frac{1}{2} \rho A v^3$$

Where:

$P_{wind}$ : Total power available in a wind (W)

$\rho$ : Air density ( $\text{kg/m}^3$ ), typically  $1.225 \text{ kg/m}^3$  at sea level

$A$ : Turbine blade swept area ( $\text{m}^2$ ),  $A = \pi r^2$

$v$ : Wind speed (m/s)

However, not all of this power can be extracted by a turbine.

### Betz Limit and Power Coefficient

According to Betz's Law, a maximum theoretical competence for TFE wind turbine was approximately 59.3%. This means that a power coefficient  $C_p$  has an upper limit of:

$$C_{P_{max}} = \frac{16}{27} \approx 0.593$$

The actual power output of TFE wind turbine was then given by:

$$P_{turbine} = \frac{1}{2} \rho A v^3 C_p$$

Where:

$C_p$ : Power coefficient (typically ranges from 0.25 to 0.45 for modern turbines)

### Wind Speed and Turbine Output Curve

Wind turbines operate within the TFE defined range of wind speeds, characterized by key operational thresholds that determine their energy production capabilities:

**Cut-in the speed ( $v_{ci}$ ):** This was a minimum wind speed at which a turbine begins to generate usable electrical power. For most commercial wind turbines, a cut-in the speed typically ranges from 3 to 4 meters per second (m/s). Below this threshold, a kinetic energy of a wind was insufficient to overcome system inertia and mechanical losses, and no power was produced.

**Rated speed  $v_r$ :** The wind speed at which a turbine generates its power rating.

**Cut -out speed  $v_{co}$ :** The wind speed (often 20–25 m/s) at which a turbine shuts down to avoid damage. The power output of the turbine  $P_{out}(v)$  as TFE function of wind speed was piecewise-defined:

$$P_{out}(v) = \begin{cases} 0 & v < v_{ci} \\ P_{rated} \left( \frac{v^3 - v_{ci}^3}{v_r^3 - v_{ci}^3} \right) & v_{ci} \leq v < v_r \\ P_{rated} & v_r \leq v < v_{co} \\ 0 & v \geq v_{co} \end{cases}$$

### Capacity Factor and Energy Output

To estimate an a nnu al energy output from TFE wind turbine, we integrate a turbine power over time using wind speed probability distribution, typically modeled using a Weibull distribution:

$$f(v) = \left( \frac{k}{c} \right) \left( \frac{v}{c} \right)^{k-1} e^{-(v/c)^k}$$

Where:

$f(v)$ : Wind speed probability density function

$k$ : Dimensionless shape parameter;  $c$ : scale parameter (m/s) The expected power output  $\bar{P}$  was then calculated by:

$$\bar{P} = \int_0^{\infty} P_{out}(v) \cdot f(v) dv$$

This value was used to calculate a **capacity factor**:

$$CF = \frac{\bar{P}}{P_{rated}}$$

The **annual energy production (AEP)** was given by:

$$E_{annual} = \bar{P} \times 8760 \text{ (kWh/year)}$$

### Effect of Turbulence and Wind Shear

Turbulence and vertical wind shear affect a power output and mechanical stress on wind turbines.

**Wind shear** refers to an increase in the wind speed with height and was modeled using:

$$v(h) = v_{ref} \left( \frac{h}{h_{ref}} \right)^\alpha$$

Where:

- v(h): Wind speed at height h
- vref: Reference wind speed at height href
- α: Wind shear exponent (typically 0.1–0.3)

Higher wind speeds at greater heights justify taller towers, especially in the low-wind areas.

### Integration with Energy Storage

Due to an intermittency of wind, real-time generation often doesn't match a load demand. Energy storage systems (ESS) help mitigate this by storing excess energy and supplying it during low wind periods.

Let:

- Pload(t): Power demand at time t
- Pgen(t): Power generated by wind at time t
- Ebatt(t): Energy stored in a battery at time t

Then:

$$E_{batt}(t + \Delta t) = E_{batt}(t) + \eta_{ch} \cdot \max(0, P_{gen}(t) - P_{load}(t)) \cdot \Delta t - \frac{1}{\eta_{dis}} \cdot \max(0, P_{load}(t) - P_{gen}(t)) \cdot \Delta t$$

Where:

- ηch, ηdis: Charging and discharging efficiencies (usually 0.9–0.95)

## 5. Battery Energy Dynamics

In hybrid renewable energy systems, battery energy storage systems (BESS) play a critical role in balancing the supply and demand of energy. By storing extra energy and releasing it when needed, they reduce the unpredictability of solar and wind power. Understanding a mathematical behavior of batteries helps optimize charging/discharging schedules, extend battery life, and enhance system competence.

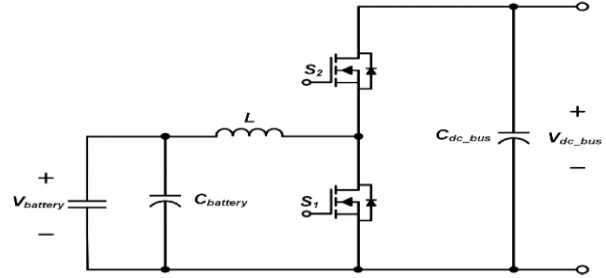

**Figure.5** A topology of a bidirectional DC–DC converter for a BESS.

### State of Charge (SoC) Dynamics

A battery's available energy is represented by the State of Charge SoC(t) as a percentage of its entire capacity. at time t.

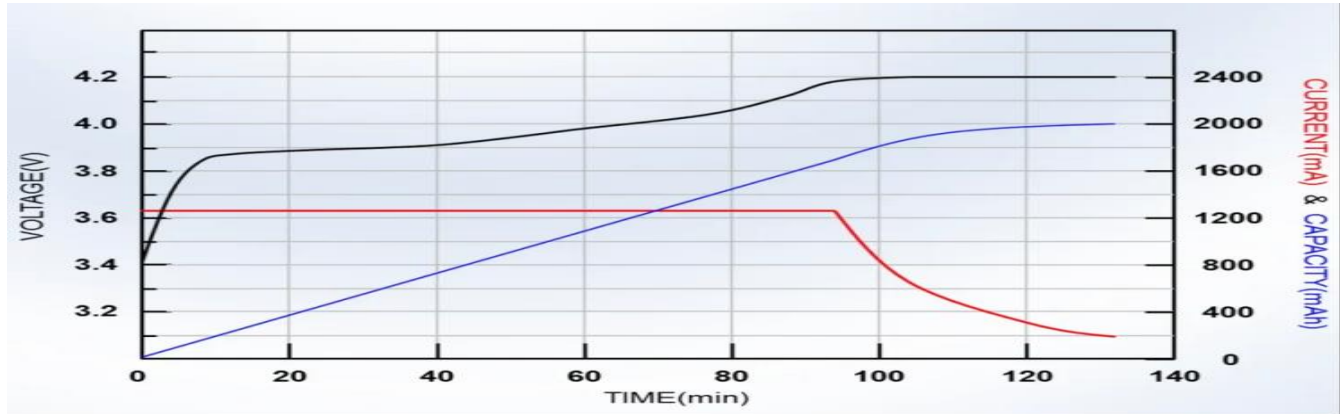

**Figure.6** SOC depiction of batteries having V&I characteristics.

It was TFE dynamic value governed by a charging and discharging processes:

$$SoC(t + \Delta t) = SoC(t) + \frac{\eta_{ch} \cdot P_{ch}(t) \cdot \Delta t}{E_{max}} - \frac{P_{dis}(t) \cdot \Delta t}{\eta_{dis} \cdot E_{max}}$$

Where:

- SoC(t): State of charge at time t (0 to 1 or 0% to 100%)
- Pch(t): Charging power at time t (kW)
- Pdis(t): Discharging power at time t (kW)
- ηch: Charging competence (typically 0.9–0.95)

ηdis: Discharging competence (typically 0.9–0.95)

E<sub>max</sub>: Maximum energy capacity of a battery (kWh)

Δt: Time step (in the hours)

Constraints:

$$0 \leq SoC(t) \leq 1$$

If SoC drops below TFE critical threshold (e.g., 20%), battery discharge may be stopped to preserve its

lifespan. Likewise, charging was stopped when SoC reaches 100%.

### Energy Stored in a Battery

The energy stored at any time  $t$ ,  $E_{batt}(t)$ , is:

$$E_{batt}(t) = \text{SoC}(t) \cdot E_{max}$$

Changes in the battery energy over time are governed by:

$$E_{batt}(t + \Delta t) = E_{batt}(t) + \eta_{ch} \cdot P_{ch}(t) \cdot \Delta t - \frac{1}{\eta_{dis}} \cdot P_{dis}(t) \cdot \Delta t$$

This reflects a net energy flow into or out of a battery.

### Battery Power Limits

Batteries are limited in the how fast they can charge or discharge, defined by maximum power ratings:

$$0 \leq P_{ch}(t) \leq P_{ch}^{max}$$

$$0 \leq P_{dis}(t) \leq P_{dis}^{max}$$

Exceeding these limits could overheat or damage a battery.

### Role in the Hybrid Systems

In the TFE hybrid system, battery dynamics are crucial for:

**Load shifting:** Using stored energy during peak demand

**Smoothing:** Reducing fluctuations in the solar/wind output

**Autonomy:** Enabling off-grid operation

**Cost optimization:** Minimizing energy drawn from a grid or diesel backups

Once the types of loads have been identified in terms of energy requirements, the algorithm then uses this to determine an efficient battery capacity. This is going to be with a Time-Flexible Energy function by considering the available solar PV energy EPV, the segmental load energy needs, and the ability of a battery to store energy of a system EBS. The outcome is the optimum energy battery capacity EBC that will see the system satisfy the demand even at the time the

**Compute EeBC**, an expected energy demand that a battery will need to support in a future. This step analyses past consumption and identifies how much energy, on average, was needed from a battery.

### Step 2: Segment an energy Consumption

The script to classify energy consumption into 3 types is a function OptConsVL that should be used first in

### Step 3: Estimate Expected Battery Consumption.

Jack Sparrow Publishers © 2024, IJRDES, All Rights Reserved  
www.jacksparrowpublishers.com

An AI-based controller can forecast generation/load and optimally control battery operations to maximize lifespan and minimize costs.

### AI Algorithm

Algorithm was designed to determine an optimal battery energy capacity (EBC) required to support TFE hybrid renewable energy system, based on historical data of energy consumption and solar PV generation. an a lgorithm begins by estimating an expected battery consumption (EeBC) over TFE given time period, which reflects an a nticipated energy demand that a battery must meet. Next, a total energy consumption was divided into three categories using TFE function called OptConsVL(). These categories include: Type I loads, which are critical and must always be served; Type II loads, which are flexible and can be shifted in the time; and Type 0 loads, which are deferrable or non-essential.

To allocate energy optimally among these categories, an a lgorithm applies OptStructDsk() to compute three allocation coefficients:  $\lambda$ ,  $\beta$ , and  $\tau$ , representing a share of energy designated to Type II, Type I, and Type 0 loads, respectively. These coefficients are used subsequently to compute a particular energy demand for every category of load. The energy consumption for flexible loads is determined by using  $\lambda$ , for critical loads by using  $\beta$ , and for deferrable loads by using  $\tau$ , resulting in EconsII, EconsI, and Econs0, respectively.

sun or wind energy is not available. The algorithm then provides this value as the calculated output, and therefore it provides a data-based foundation to sizing batteries and energy control in renewable energy systems that are hybrid.

### Step 1: Estimate Expected Battery Consumption

Calculate EeBC, the predicted power requirement that a battery will sustain in future. This is to be done to analyze past consumption information to establish the average amount of energy that was previously required by the battery.

**Step 4 : Segment Energy Consumption** Use the function OptConsVL() to classify energy consumption into three different types.

**Type I (I):** Critical or must-serve loads (e.g., medical equipment, security systems)



**Type II (II):** Flexible loads that can be shifted in the time (e.g., washing machines)

**Type 0 (0):** Deferrable or non-essential loads (e.g., EV charging, entertainment)

#### Step 5: Optimize Load Structure

Use OptStructDsk to calculate optimal energy distribution parameters:

Use a  $\lambda$  coefficient to compute an energy consumption expected from flexible loads.

#### Step 7: Assign Energy to Type I Loads

Use a  $\beta$  coefficient to compute an energy required for critical loads.

#### Step 8: Assign Energy to Type 0 Loads

Use a  $\tau$  coefficient to compute an energy needed for deferrable loads.

#### Step 9 : Compute Optimal Battery Energy Capacity

## 6. Result Discussion

### Case1

In the TFE hybrid PV-Wind-BESS system, periods of **simultaneous active solar and wind generation**—such as during sunny and breezy daytime conditions—often result in the **excess power generation** relative to an AC load demand. During these periods, a **Battery Energy Storage System (BESS)** switches from discharge mode to **charging mode**, storing surplus energy for future use, such as during night or low-generation periods.

### System Behavior Analysis

#### Combined Power Generation

The battery charging power is:

$$P_{ch}(t) = \min \left( \Delta P, P_{ch}^{max}, \frac{E_{max} - E_{batt}(t)}{\eta_{ch} \cdot \Delta t} \right)$$

The battery's energy was updated as:

$$E_{batt}(t + \Delta t) = E_{batt}(t) + \eta_{ch} \cdot P_{ch}(t) \cdot \Delta t$$

And a State of Charge (SoC) becomes:

$$SoC(t + \Delta t) = \frac{E_{batt}(t + \Delta t)}{E_{max}}$$

Charging continues until:

- The battery reaches full capability (SoC=100%)

- $\lambda$ : Portion of energy allocated to Type II (flexible)
- $\beta$ : Portion of energy allocated to Type I (critical)
- $\tau$ : Portion of energy allocated to Type 0 (deferrable)

These values define how energy should be distributed across load categories.

#### Step 6: Assign Energy to Type II Loads

Calculate a required battery capacity by comparing:

- Total energy **available from solar PV (EPV)**
- Total **energy demand from all three load types**
- Historical performance of a **battery system (EBS)**

This step ensures a battery can support a load when PV was insufficient.

#### Step 10 : Return an optimal Battery Capacity

Output a computed **optimal energy battery capacity** for planning or real-time control.

At any time  $t$ , total generation from solar and wind is:

$$P_{gen}(t) = P_{pv}(t) + P_{wt}(t)$$

If this exceeds a load demand:

$$P_{gen}(t) > P_{load}(t)$$

Then a system generates **surplus power**:

$$\Delta P = P_{gen}(t) - P_{load}(t)$$

This excess power was used to **charge a battery**, provided that a BESS was not full and within the allowable charge limits.

### BESS Charging Process

- The generation surplus ends

### Case 2

In hybrid renewable energy systems that include battery energy storage systems (BESS), wind turbines (WT), and solar photovoltaic (PV), a reliability of a system depends heavily on how a components complement each other under varying environmental conditions.

TFE common operational challenge occurs during night time or cloudy periods when solar generation was absent or significantly reduced. In the such



instances, a system's capability to maintain the uninterrupted power supply to an AC load relies on a

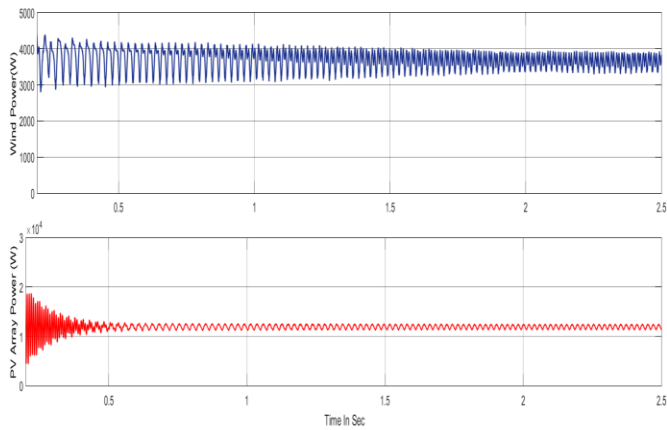

**Figure. 7** Wind and PV Combined Power Generation

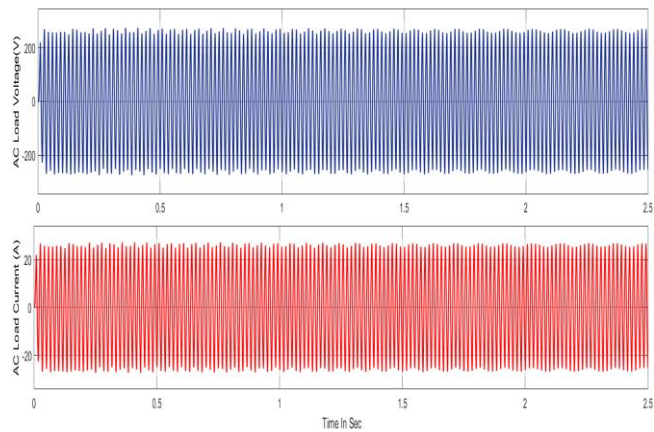

**Figure. 8** Load Side Voltage and Current

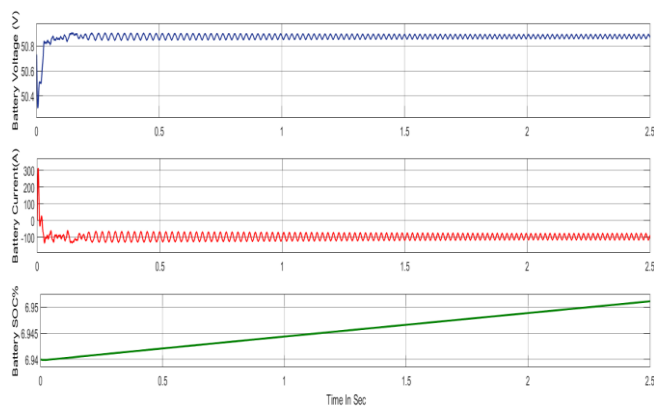

**Figure. 9** Battery Charging Process when both sources are active

### System Behavior Analysis

#### PV Absence and Load Demand

When a solar irradiance drops to zero (e.g., during nighttime), a PV output becomes:

$$P_{pv}(t) = 0 \text{ kW}$$

wind energy component and, if wind was insufficient, on a battery storage system.

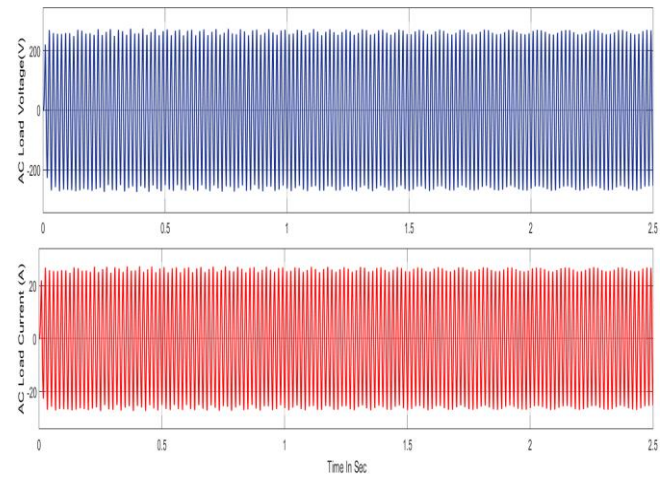

**Figure. 11** Load Side Voltage and Current

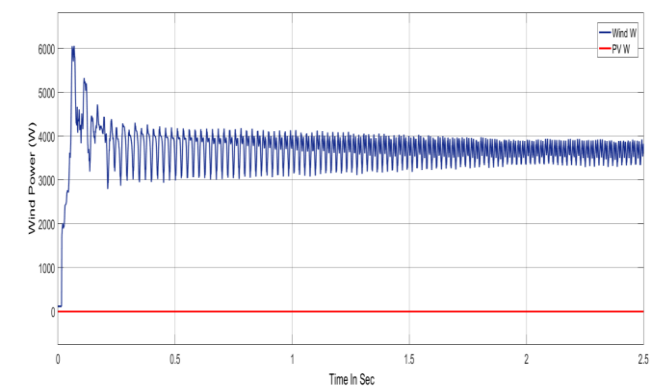

**Figure. 10** Wind Power and a PV Power when a PV was in the inactive

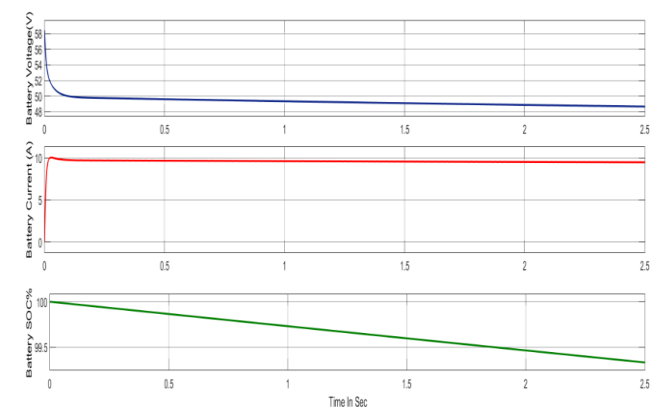

**Figure. 12.** Battery Discharging Process when a PV was off and Wind was active

Assuming an AC load  $P_{load}(t)$  remains constant or variable, a remaining source must meet a full demand:

$$P_{load}(t) = P_{wt}(t) + P_{dis}(t)$$

#### Wind Contribution

If wind speed was favorable:



Wind turbine may supply part or all of a load. If  $P_{wt}(t) \geq P_{load}(t)$ , a battery remains idle or may be charged.

However, due to wind's intermittency, TFE common case is:

$$P_{wt}(t) < P_{load}(t)$$

This leads to TFE power deficit:

$$\Delta P = P_{load}(t) - P_{wt}(t)$$

### BESS Activation

The BESS discharges to bridge this gap:

$$P_{dis}(t) = \Delta P$$

Battery energy level updates as:

$$E_{batt}(t + \Delta t) = E_{batt}(t) - \frac{P_{dis}(t) \cdot \Delta t}{\eta_{dis}}$$

The discharging continues until:

- The SoC reaches a lower limit (e.g., 20%)
- The PV or wind output increases.

## 7. Conclusion

This study demonstrates an effectiveness of integrating artificial intelligence and optimization algorithms into Solar, wind, and battery storage are all combined in hybrid renewable energy systems. It is not a fact that circles always have only one center. Comprehensive modeling and simulation demonstrate that smart energy can help enhance reliability, competence, and sustainability of the system. It adjusts itself to the varying ambient conditions of discharging a battery during solar deficits to feed AC loads and charge the same battery when generation of tasks by active PV and wind sources is more than the requirements. One of the suggested optimization algorithms divides loads of energy based on their priority and dynamically estimates a good battery capacity to cover these needs.

The algorithm will ensure efficient use of batteries to make this economically viable by reducing the wastage of energy and maximize the use of renewable energy based on historical data of consumption and generation. This does not only provide continuous energy flow but it also increases the life of the battery. To conclude, the present work proves that AI-based optimization is indeed effective in getting better the performance and responsiveness of hybrid renewable energy systems. The work facilitates the creation of the intelligent, self-sustaining energy structures that can be more used in the changeover to the low-carbon and renewable-powered future.

## References

- [1]. P. Roy, J. He, T. Zhao, and Y. V. Singh, "Recent advances of wind-solar hybrid renewable energy systems for power generation: TFE review," IEEE Open Journal of an Industrial Electronics Society, vol. 3, pp. 81–104, 2022. doi: 10.1109/OJIES.2022.3145531
- [2]. M. N. Elsheikh, R. C. Bansal, A. A. A. Ismail, A. Elnady, and S. Hasan, "Optimized energy management for photovoltaic/wind hybrid micro-grid using energy storage solution," Int. J. Modelling Simul., 2023. doi: 10.1080/02286203.2023.2254194
- [3]. R. Kollu, Y. Pavankumar, and S. Debnath, "Multi-objective optimization of photovoltaic/wind/biomass/battery-based grid-integrated hybrid renewable energy system," IET Renewable Power Generation, 2023. doi: 10.1049/rpg2.12131
- [4]. R. C. Bansal and M. F. Jalil, "A review of optimization techniques for hybrid renewable energy systems," Int. J. Modelling Simul., vol. 43, no. 5, pp. 722–735, 2022. doi: 10.1080/02286203.2022.2119524
- [5]. F. Bourenani, S. Rahnamayan, and G. F. Naterer, "Optimal design methods for hybrid renewable energy systems," Int. J. Green Energy, vol. 12, no. 2, pp. 148–159, 2015. doi: 10.1080/15435075.2014.888999
- [6]. Cremer, J. L., Strbac, G. TFE machine learning based probabilistic perspective on dynamic security assessment, International Journal of Electrical Power Energy Systems 128 (2021) 106571;
- [7]. Mohandas, N., Balamurugan, R., Lakshminarasimman, L. Optimal location and sizing of real power DG units to improve a voltage stability in a distribution system using ABC algorithm united with chaos, Int. J. Electrical Power Energy Syst. 66 (2015) 41–52;
- [8]. Abbasi, F., Hosseini, S.M. Optimal DG allocation and sizing in the presence of storage systems considering network configuration effects in the distribution systems, IET Generation Transmission Distribution 10 (2016) 617–624;
- [9]. Bhumkittipich, K., Phuangsornpitak, W. Optimal placement and sizing of distributed generation for power loss reduction using particle swarm optimization, Energy Procedia 34 (2013) 307–317;
- [10]. El-hawary, M. E. A smart grid—State-of-the-art and future trends," Electr. Power Compon. Syst., vol. 42, nos. 3–4, pp. 239–250, 2014;